

# FLM input modules

## Installation manual

R9854430 - R9854440  
R9854450 - R9854460  
R9854435 - R9854465

**Barco nv Events**

Noordlaan 5, B-8520 Kurne

Phone: +32 56.36.89.70

Fax: +32 56.36.88.24

E-mail: [sales.events@barco.com](mailto:sales.events@barco.com)

Visit us at the web: [www.barco.com](http://www.barco.com)

---

# TABLE OF CONTENTS

<b>1. FLM input modules</b> .....	<b>3</b>
1.1 Available input modules .....	3
1.2 Switching off .....	3
1.3 Removal of an input module .....	4
1.4 Installation of an input module .....	5
<b>2. Specifications</b> .....	<b>7</b>
2.1 Specifications FLM DVI input .....	7
2.2 Specifications FLM DVI HDCP input.....	7
2.3 Specifications FLM HDSI – SDI input.....	8
2.4 Specifications FLM High bandwidth data input (RGB) .....	8
2.5 Specifications FLM 5 cable input (multi purpose) .....	9



# 1. FLM INPUT MODULES

## General

This installation manual enumerates all available input modules for the FLM projector and describes how to install the input modules. Furthermore, the specifications are listed per input module. Note that only one input module is included in this kit together with this manual.

## 1.1 Available input modules

### Available

Order No.	Description
R9854430	5 cable input
R9854435	5 cable input /2
R9854440	RGB input
R9854450	HD-SDI/SDI input
R9854460	DVI input
R9854465	HDCP DVI input



Image 1-1  
5 Cable input (Multi purpose) (R9854430).



Image 1-2  
5 Cable input (Multi purpose) (R9854435).



Image 1-3  
High bandwidth data input (RGB) (R9854440).



Image 1-4  
HDSDI - SDI input (R9854450).



Image 1-5  
DVI input (R9854460).



Image 1-6  
HDCP DVI input (R9854465).

## 1.2 Switching off

### How to switch off the projector?

1. Press first **Standby**.
2. Let cool down the projector until the fans decrease, at least 5 min.
3. Switch off the projector with the power switch.

## 1.3 Removal of an input module



The procedure below is applicable to all input modules of the input & communication unit of the projector.

### Necessary tools

Phillips screw driver PH1.

### How to remove an input module out of the input & communication unit of the projector ?

1. Switch off the projector and unplug the power cord at the projector side.
2. Release the two captive screws of the input module using a Phillips screw driver PH1. (image 1-7)
3. Pull the input module out of the input & communication unit, via the two knobs provided. (image 1-8)

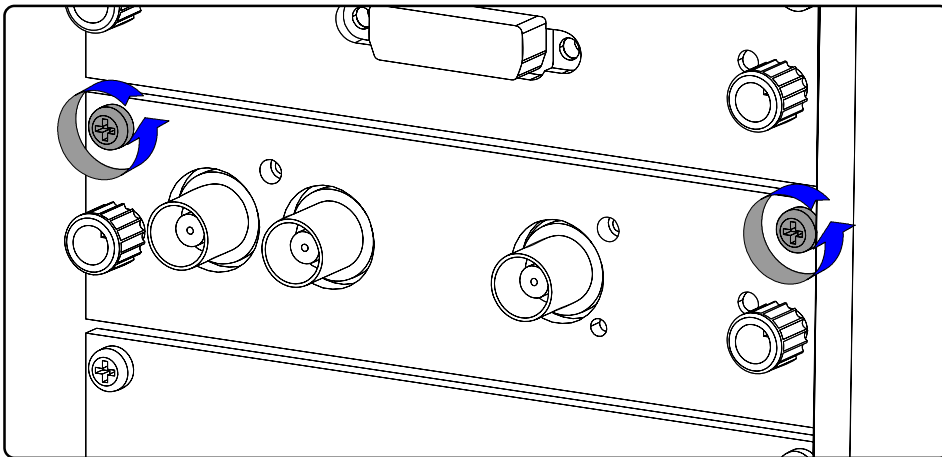

Image 1-7

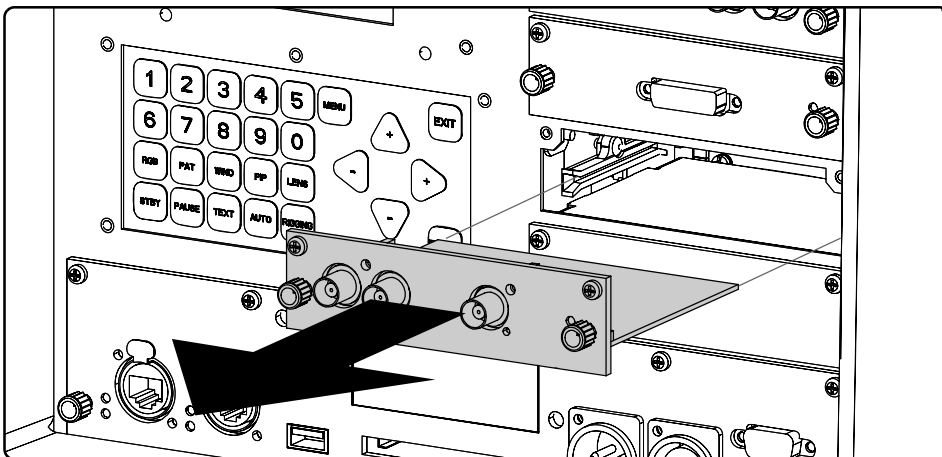

Image 1-8



**CAUTION:** Ensure that all unused input slots of the input & communication unit are always covered with a dummy front plate. After removing one of the input modules, immediately replace with an other one or install a dummy front cover on the unused input slot.

## 1.4 Installation of an input module



The procedure below is applicable to all input modules of the input & communication unit of the projector.

### Necessary tools

Phillips screw driver PH1.

### How to install an input module into the input & communication unit of the projector ?

1. Switch off the projector and unplug the power cord at the projector side.
2. Slide the input module into the guides of the input slot. (image 1-9)
3. Push the input module forward until you feel that the connector of the input module fit in the socket of the input slot. The back of the front plate of the module must touch the front plate of the input & communication unit.
4. Secure the input module by fastening both captive screws in the top corners of the module. (image 1-10)

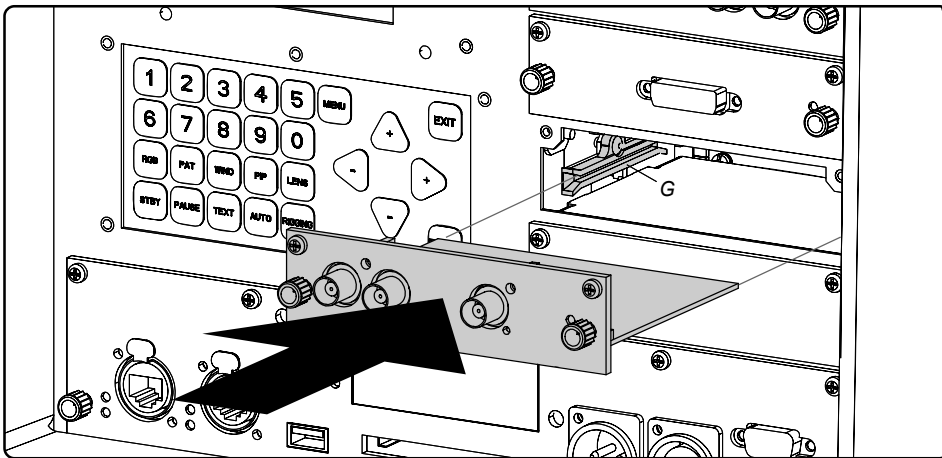

Image 1-9

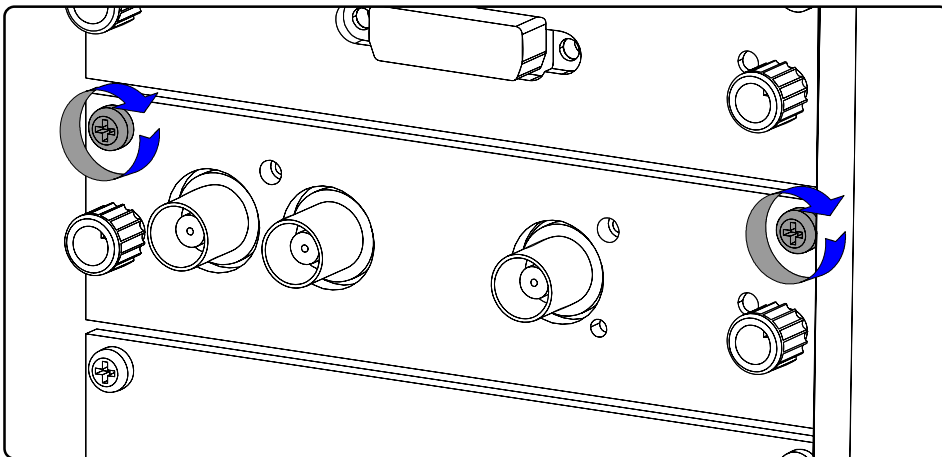

Image 1-10



## 2. SPECIFICATIONS

### 2.1 Specifications FLM DVI input

#### Input front view

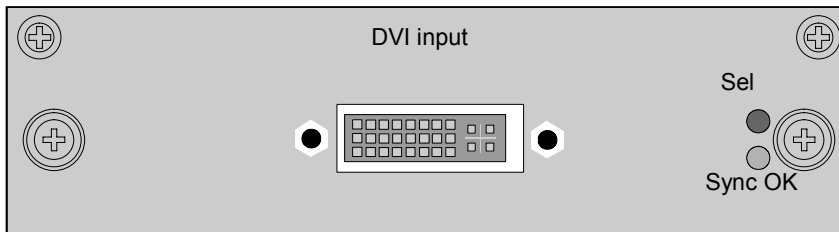

Image 2-1

#### Specifications

- DVI type: DVI-I (DVI-Integrated), but the analog signals are not supported. Single-link configuration.
- Single link dvi for pixelclocks up to 165MHz
- Vertical frequencies: 24 - 75 Hz
- Horizontal frequencies: 20 - 90 kHz
- Supported resolutions: up to UXGA (1600 x 1200) at 60 Hz.
- Cable lengths: up to 3 meter at UXGA speed.
- Compliance: DDC2B support according to VESA EDID Version 1.2
- Diagnostic LED's on front panel:
  - Green LED: Lights up in case input module is selected
  - Yellow LED: Lights up in case sync detected

### 2.2 Specifications FLM DVI HDCP input

#### Input front view

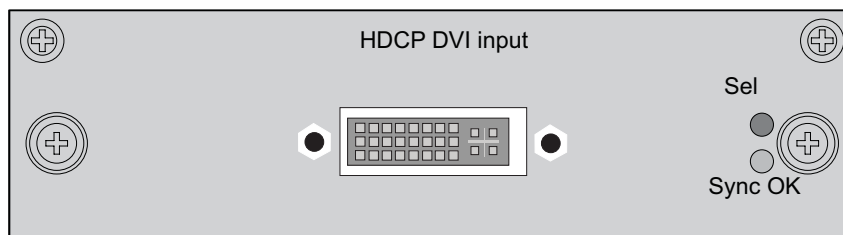

Image 2-2

#### Specifications

- DVI type: DVI-I (DVI-Integrated), but the analog signals are not supported. Single-link configuration.
- Supports UXGA Resolution (1600 x 1200) (Output Pixel Rates up to 165 MHz)
- True-Color, 24 Bits/Pixel, 48-Bit Dual Pixel Output Mode, 16.7M Colors at 1 or 2 Pixels Per Clock
- Digital Visual Interface (DVI) and High-Bandwidth Digital Content Protection (HDCP) Specification Compliant
- Vertical frequencies: 24 - 75 Hz
- Horizontal frequencies: 20 - 90 kHz
- Cable lengths: up to 3 meter at UXGA speed.
- Compliance: DDC2B support according to VESA EDID Version 1.2
- Diagnostic LED's on front panel:
  - Green LED: Lights up in case input module is selected
  - Yellow LED: Lights up in case sync detected

## 2.3 Specifications FLM HDSDI – SDI input

### Input front view HDSDI – SDI input

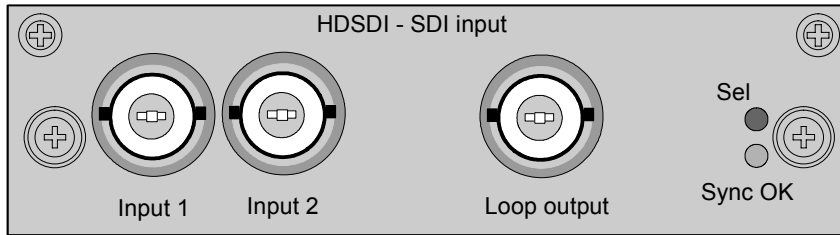

Image 2-3

### Specifications

- SD SMPTE 259M-C and HD SMPTE 292M input data
- 2 inputs (BNC), 1 active loop-through output (BNC) of selected input
- Automatic selection of active input with manual override
- 10 bit digital output
- Diagnostic LED's on front panel:
  - Green LED: Lights up in case input module is selected
  - Yellow LED: Lights up in case sync detected
- SDI: 270 Mbit/s transmission (SMPTE 259M-C).
- SDI: 525/625 interlaced.
- Coax (75 Ohm).
- Supported HDSDI standards:
  - Progressive:
    - o 1280x720/60/1:1/ (SMPTE 296M)
    - o 1280x720/59.94/1:1/ (SMPTE 296M)
    - o 1920x1080/30/1:1/ (SMPTE 274M)
    - o 1920x1080/29.97/1:1/ (SMPTE 274M)
    - o 1920x1080/25/1:1/ (SMPTE 274M)
    - o 1920x1080/24/1:1/ (SMPTE 274M)
    - o 1920x1080/23.98/1:1/ (SMPTE 274M)
  - Interlaced:
    - o 1920x1035/60/2:1/ (SMPTE 260M)
    - o 1920x1035/59.94/2:1/ (SMPTE 260M)
    - o 1920x1080/60/2:1/ (SMPTE 274M)
    - o 1920x1080/59.94/2:1/ (SMPTE 274M)
    - o 1920x1080/50/2:1/ (SMPTE 274M)
    - o 1920/1080/50/2:1 (1250)/ (SMPTE 295M)
    - o 1920x1080/24/Segmented/ (SMPTE 274M)
    - o 1920x1080//23.98/Segmented/ (SMPTE 274M)

## 2.4 Specifications FLM High bandwidth data input (RGB)

### Input front view

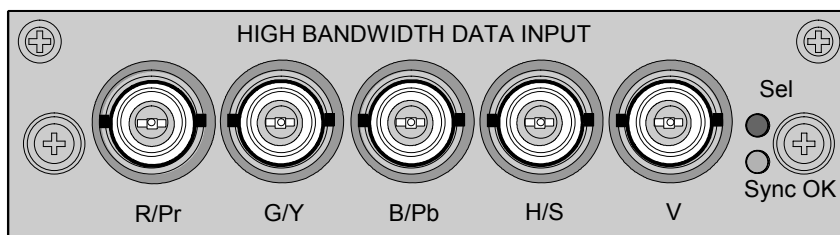

Image 2-4

**Signal connectivity**

Input signal	R / P <sub>R</sub>	G / Y	B / P <sub>B</sub>	H / S	V
RGBHV	R	G	B	H	V
RGBS	R	G	B	S	—
RGsB	R	G <sub>s</sub> sync on green	B	—	—
Component Video - SS	P <sub>R</sub> / (R - Y)	Y	P <sub>B</sub> / (B - Y)	S	—
Component Video - SOY	P <sub>R</sub> / (R - Y)	Y <sub>s</sub>	P <sub>B</sub> / (B - Y)	—	—

**Specifications**

- Data and HD sources RGB and YUV [HS/VS, CS or SOG(Y)]:
  - pixelclock maximum 275MHz
  - 8 bit digital output
- Mode configurations:
  - RGB HS/VS - CS, RGB SOG
  - YUV HS/VS - CS, YUV SOY
- Possible to disconnect 75 Ohm terminations on HS and VS (TTL sync level selection)
- Signal requirements:
  - Component Video (BNC)
    - o R-Y : 0,7Vpp ±3dB 75 Ohm termination.
    - o Y<sub>s</sub> : 1Vpp ±3dB (0,7V Luma +0,3V Sync) 75 Ohm termination.
    - o B-Y : 0,7Vpp ±3dB 75 Ohm termination.
  - RG(s)B
    - o R : 0,7Vpp ±3dB 75 Ohm termination.
    - o G(s) : 1Vpp ±3dB (0,7Vpp G + 0,3Vpp Sync) 75 Ohm termination.
    - o B : 0,7Vpp ±3dB 75 Ohm termination.
- Diagnostic LED's on front panel:
  - Green LED: Lights up in case input module is selected
  - Yellow LED: Lights up in case sync detected

**2.5 Specifications FLM 5 cable input (multi purpose)****Front view 5 cable input**

Image 2-5

**Signal connectivity**

Input signal	R / P <sub>R</sub>	G / Y / VIDEO	B / P <sub>B</sub>	H / S	V / C <sub>R</sub>
RGBHV	R	G	B	H	V
RGBS	R	G	B	S	—
				composite sync or VIDEO as sync	

## 2. Specifications

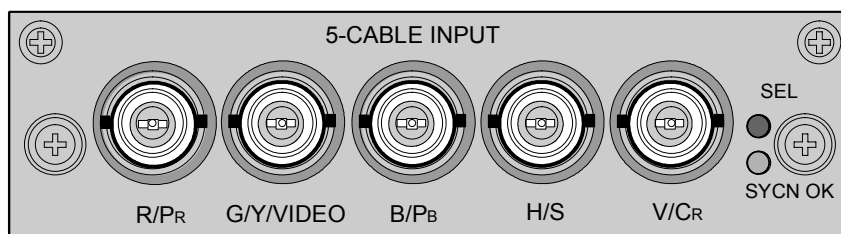
Input signal	R / P <sub>R</sub>	G / Y / VIDEO	B / P <sub>B</sub>	H / S	V / C <sub>R</sub>
RGsB	R	Gs sync on green	B	—	—
Composite Video	—	VIDEO	—	—	—
Super Video	—	Y Luma	—	—	C Chroma
Component Video - SS	P <sub>R</sub> / (R - Y)	Y	P <sub>B</sub> / (B - Y)	S composite sync or VIDEO as sync	—
Component Video - SOY	P <sub>R</sub> / (R - Y)	Ys	P <sub>B</sub> / (B - Y)	—	—

### Specifications

- Data and HD sources RGB and YUV [HS/VS, CS or SOG(Y)]:
  - Pixel clock maximum 275 MHz
  - 8 bit digital output
- Video sources CVBS, S-VIDEO, RGB and YUV [CS, CV or SOG(Y)]:
  - PAL B/D/I/G/H, PAL60, PAL M, PAL N, PAL Nc
  - NTSC M/J, NTSC 4.43
  - SECAM B/D/G/K/L
  - 525i, 625i, 525p, 625p
  - Macrovision copy protection robust
  - 10 bit digital output
  - Standard images "video525" and "video625"
- Automatic detection of sync inputs but with manual override:
  - automatic modes : RGB, YUV, VIDEO
  - manual modes : RGB HS/VS - CS, RGB CV, RGB SOG, YUV HS/VS - CS, YUV CV, YUV SOY, CVBS, S-VIDEO
- Possible to disconnect 75 Ohm terminations on HS and VS (TTL sync level selection)
- Signal requirements:
  - Component Video (BNC)
    - o R-Y : 0,7Vpp ±3dB 75 Ohm termination.
    - o Ys : 1Vpp ±3dB (0,7V Luma +0,3V Sync) 75 Ohm termination.
    - o B-Y : 0,7Vpp ±3dB 75 Ohm termination.
  - RG(s)B
    - o R : 0,7Vpp ±3dB 75 Ohm termination.
    - o G(s) : 1Vpp ±3dB (0,7Vpp G + 0,3Vpp Sync) 75 Ohm termination.
    - o B : 0,7Vpp ±3dB 75 Ohm termination.
- Diagnostic LED's on front panel:
  - Green LED: Lights up in case input module is selected
  - Yellow LED: Lights up in case sync detected